

# ELGIN

## CSI Cyclone™ Vertical Cuttings Dryers



The Industry's Most Recognized Turn-Key  
Waste Cuttings Management Solution

Natural Resource Recycling • Product Classification • Dewatering • Fluid Recovery  
Waste Management • Material Handling • Liquid/Solid Separation • Crushers • Feeders

**TERRASOURCE**  
GLOBAL  
OUR FLAGSHIP BRANDS  
   



CSI-D4 Cyclone Pro™

## Turn-Key Waste Cuttings Solution

Since 2000, CSI™ has been the industry's most recognized & reputable Vertical Cuttings Dryer (VCD) available in the market. No other brand has achieved more success or recovered more drilling fluid, than the CSI Cyclone™ VCD. There have been more than 850 dryers delivered to the market.

Every major solids control & waste management service provider in the market operate CSI Cyclone™ dryers (including, but not limited to Baker Hughes™, Halliburton™, M-I Swaco™, Weatherford™, Ava / New Park™ and NOV™\*).

VCD applications are driven by three key objectives:

- Drilling Fluid Reclamation
- Waste Solid Reduction
- Waste Solid Declassification

A properly deployed Vertical Cuttings Dryer ("VCD"), can significantly reduce waste disposal costs, dramatically lower whole mud loses within those wastes, and improve the overall quality of the drilling fluid by allowing the shale shakers and centrifuges to be used at their full operating potential.

\* BAKER HUGHES™, HALLIBURTON™, M-I SWACO™, WEATHERFORD™, AVA/NEWPARK™, and NOV™ are proprietary trademarks of their owners National Oilwell Varco, Inc., M-I LLC (a Schlumberger Company), Baker Hughes, Weatherford, and Ava S.P.A.™, respectively. The marks, corresponding products and owners are not affiliated with Elgin Separation Solutions, Elgin Power Solutions or Elgin Power and Separation Solutions. \*Competitor data was sourced from marketing data provided by the applicable manufacturers.





## Drilling Fluid Reclamation

VCD's recover OBM and WBM from drill cuttings discharged from the flow line shakers. Shakers can discharge cuttings that are up to 30% by weight "wet". When unrecovered, this lost fluid will cost the rig thousands per day. Elgin's CSI Cyclone™ dryers can achieve a 4% oil-on-cuttings ("OOC") when operating at peak performance.

## Waste Solid Reduction

By reclaiming drilling fluid from the cuttings, the overall volume (or weight) of the cuttings is lowered, therefore lowering transport and disposal costs by the same percentage of fluid recovery, generating further savings.

## Waste Solid Declassification

Depending on the rig site (offshore vs. onshore), or even on the region in which the drilling activity is occurring, the reduction of the fluid content can lower the hazard classification of the waste solids.

Each system can be supplied with feed and discharge conveyors, a cuttings feed pump, feed hoppers, and/or a support stand (Standard configuration that includes wrap-around decks/walkways, discharge chute, hand-rails, and jib pole).

*The application of a VCD is driven by return on investment generated from the key objectives.*

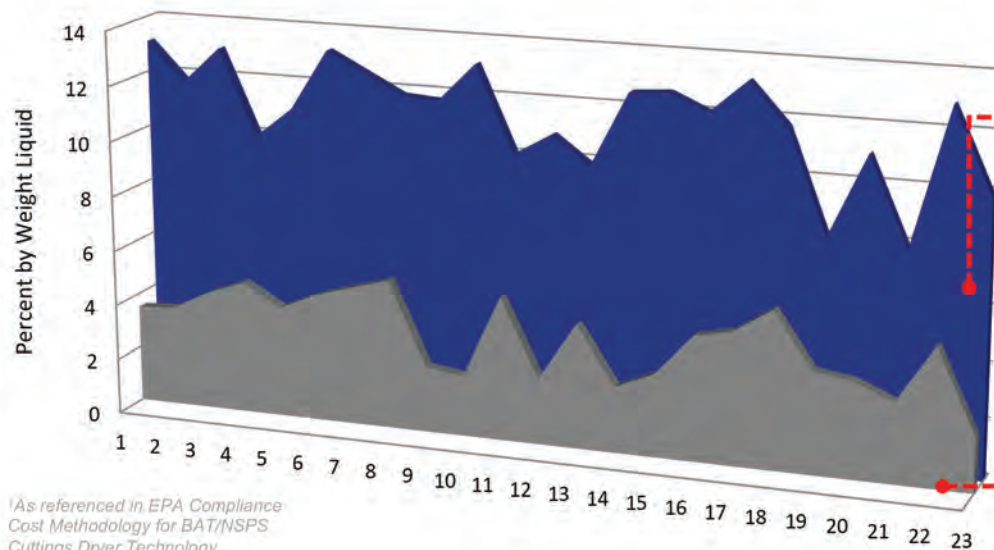

As referenced in EPA Compliance Cost Methodology for BAT/NSPS Cuttings Dryer Technology, performance data from 23 wells revealed that the Synthetic Oil Cuttings (SOC) was reduced from 11.7% to 4.15% by weight after being processed.

- Standard VCD Discharge Liquid Content (% Weight)
- Shaker Discharge Liquid Content (% Weight)

## Considerations to Keep in Mind

- Consistent feed rates will optimize VCD performance and ensure that the system is not over-taxed. Conveyor feed is highly recommend in lieu of bucket loading.
- Cuttings transport and the solids reduction efficiency can be hampered by cuttings that are too dry. Though counter-intuitive, sometime it is best to reduce the cuttings dryness discharged from the shakers.
- VCD's operate best when the particle size distribution of the cuttings are large. Fine cuttings and clays will require additional oversight and maintenance.
- VCD's work best when applied in drilling fluid applications that are inhibited.
- Post-treatment, via centrifuge, is highly recommended to remove the fines from the centrate before being returned to the active mud system.



**BEFORE** – Drill cuttings prior to feeding through a VCD.



**AFTER** – Drill cuttings after being processed by a VCD.



## Intelligent Design



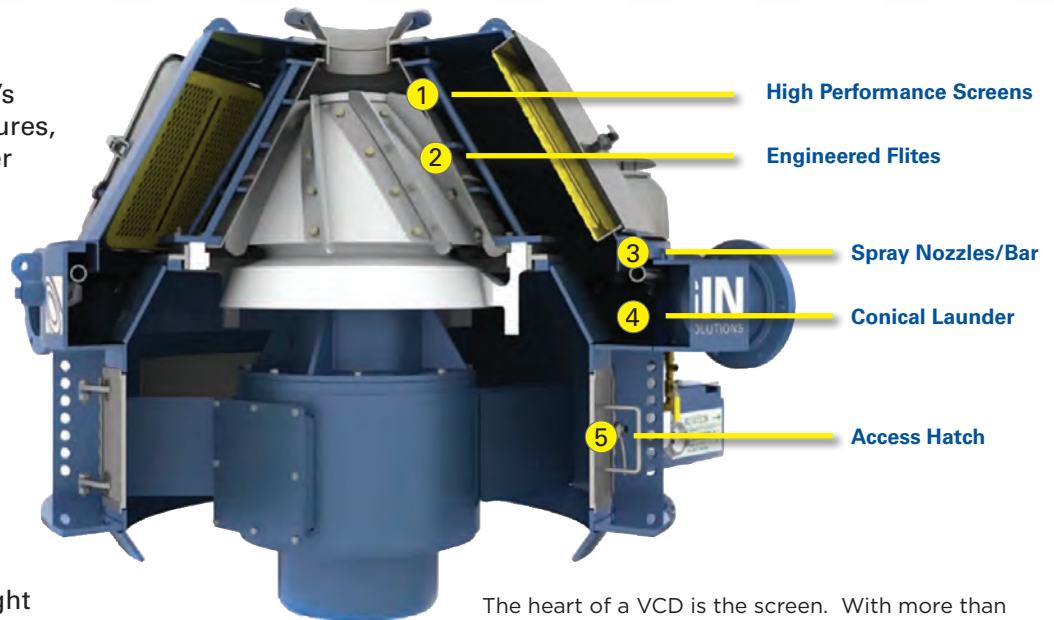

Elgin Separation Solutions VCD's incorporate several unique features, including ceramically-lined inner housing, internally mounted launder section spray bar, automatic shut-off systems, multiple access/maintenance doors, and individually balanced rotating components to ensure vibration-free operation.



Most importantly, Elgin manufactures its own host of screens and flite assemblies, further ensuring that operators have the right system for the right operating conditions.



The heart of a VCD is the screen. With more than 40 years of experience and tens-of-thousands of deployments, Elgin customers have come to rely on our premium screens for quality and durability.

### Elgin Vertical Cuttings Dryer Screen Features

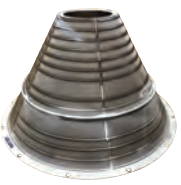
				
Enhanced abrasion resistance via proprietary chrome hardening process.	Full penetration TIG welded structure for maximum durability.	Resistance welding process for maximum consistency during production.	Dynamically balanced screen for even surface wear and mitigated system vibration.	Full stainless-steel construction for maximum corrosion resistance.

Screen Model	Material of Construction	Chrome Hardened	Welded Construction	Dynamically Balanced	Life Span
<b>Elgin Pro™ Series VCD Screens</b> 	Stainless Steel	Yes	Robotically TIG Welded	Yes	2X to 4X (Depending on Application)
<b>Elgin Classic™ Series VCD Screens</b> 	Stainless Steel	No	Resistance Welded	Yes	X





## Cyclone™ E-Series Vertical Cuttings Dryer

Elgin's CSI Cyclone™ E-Series Vertical Cuttings Dryers are the next evolution of the industry leading CSI-04™ and CSI-03™ VCD's. The new CSI Cyclone™ E-Series are designed with an improved oil-sealed gearbox drive unit that requires no active lubrication system for operation. More importantly, the new gearbox design provides for improved dryer performance when compared to their predecessors.

The most common problems causing system shutdown, during operation of traditional VCD's, is associated with the active lubrication system. Whether it is low pressure levels, exhausted filter, flow switch monitoring, fluid levels, or damaged hoses, the operation of the VCD comes to a stop. Elgin's CSI Cyclone™ E-Series Dryer eliminates active system lubrication components while increasing G-force and speed performance.

### Operating Benefits

- Reduced downtime.
- Reduced operating expense.
- Reduce gearbox repair expense.
- Reduced spare parts inventory expense.



CSI-E4 Cyclone™

### Performance Benefits

- Improved G-force output.
- Improve torque response.
- Improved differential speed.
- Improved operating temperature resilience.



**Retrofit Removes:**

- 1) Active Lubrication System
- 2) Existing Gearbox Drive Unit

**Retrofit Installs:**

- 1) Oil-Sealed Gearbox Drive Unit

*Converting your existing VCD to the oil-sealed planetary gearbox can be completed in less than day with Elgin's step-by-step guide to assist your technicians in a successful transition.*

## Higher Performance with Elgin's Oil-Sealed Planetary Gearbox Retrofit

Elgin can retrofit your existing Elgin / CSI™, Verti-G™, Typhoon™, Vortex™ and Tornado™ VCD with an enhanced three-stage, oil-sealed, planetary gearbox that requires no active lubrication system for operation, a key failure point for any vertical cuttings dryer.

By eliminating the active lubrication system, operators no longer need to worry about low pressure levels, spent oil filters, flow switch failures, low fluid levels, or damaged hoses. This also means that owners do not need to worry about the maintenance costs associated with replacement filters, lubrication oil or lube system spare parts.

Elgin's revolutionary oil-sealed planetary gearbox retrofit removes all active lubrication equipment, including the main drive gearbox, and replaces it with an oil-sealed gearbox that requires maintenance only once every six months during operation. The combination of these factors has allowed customers to achieve a 47% reduction in annual operating costs.



## Cyclone Pro™ D-Series Vertical Cuttings Dryer

Elgin's CSI Cyclone Pro™ D-Series Vertical Cuttings Dryers are the world's first, patented, dual-drive dryer. This novel technology allows operators the ability to adjust the performance of the dryer based on the nature of the solids being fed to it. Using a combination of proprietary gear boxes, operators can adjust both the applied G-force and the dwell time between the scraper flites and the screen. This technology allows the VCD to be used in both oil-based and water-based drilling fluid environments.

The most common problems causing system shutdown, during operation, is associated with the lubrication system. Whether it is low pressure levels, exhausted filter, flow switch monitoring, fluid levels, or damaged hoses, the operation of the VCD comes to a stop.

The CSI™ Cyclone Pro™ D-Series Vertical Cuttings Dryer requires no active lubrication equipment or belt drive assembly making it the perfect solution for waste cuttings management.



CSI-D4 Cyclone Pro™



The industry's only Class 1 - Division 1,  
Explosion Proof, Air-Cooled Control Panel and  
Vertical Cuttings Dryer Capable of Processing  
Water-Based and Oil-Based Cuttings

### Perfect Solution for Managing Water-Based and Oil-Based Waste Cuttings

- Designed to reduce drill cuttings moisture on waste solids by 95%.
- Recover thousands of gallons of drilling fluid and water that would normally have been disposed of with the waste drill cuttings.
- Dewatered waste solids dramatically reduce waste disposal trucking fees.
- Direct-drive technology for oil-based and water-based applications.
- Reduced maintenance costs and equipment downtime.

Not only does Elgin's technology eliminate the need to enter the dryer to service the drive belt system, but it provides guaranteed Class I – Division 1 and Class I – Division 2 compliance.





## Turn-Key Mobile System Packages

Elgin's Turn-Key Cuttings Waste Management Systems are the industry's only fully-integrated packages that ensure optimum system performance. Not only do Elgin's systems provide all of the necessary control interlocks and automation features, but they provide the safest configuration that can be deployed with the least amount of rig-up and/or assembly time. Simply provide power, and Elgin's Turn-Key Cuttings Waste Management Systems are designed to perform.

Each Turn-Key Package developed by Elgin is customized to suit the specific application needs. As Elgin is an original equipment manufacturer of VCD's, decanter centrifuges, screw conveyors, belt conveyors, explosion proof lighting systems, pump packages, and control systems, we have the flexibility and intellectual know-how to provide customized solutions, regardless of the complexity.

Elgin Manufactured, Proprietary Rack & Pinion Moveable, VFD-Adjustable Feed Rate Hopper with Screw Conveyor

Elgin Patented CSI-D4™ Vertical Cuttings Dryer

Elgin Manufactured Solids Discharge Belt Conveyor with Belt Wiper

Hydraulic Lift Cylinders Raises / Lowers Deck for Transport Ease

Progressive Cavity Feed Pump Transfers Fluid for Secondary Treatment

CSI-D4 Cyclone Pro™ Turn-Key Waste Cuttings Management System

Centrate Collection Tank with Internal Mud-Gun Agitation, High/Low Level Sensors, and Exterior Level Gauge

Proprietary Control Panel with HMI Touchscreen Controls Entire System

Elgin Manufactured On-Board Self-Priming Pump





CSI-D3 Cyclone Pro™ Containerized System



CSI-D5 Cyclone Pro™ Turn-Key Telescoping Package

Elgin's diversified product line, inclusive of lighting, pumps, and conveyors, set us apart from other non-integrated OEM's.





Model Number:	CSI-E3 Cyclone™	CSI-E4 Cyclone™
Equipment Image:		
Feed Capacity:	40 TPH (40 m³/h)	80 TPH (80 m³/h)
Maximum G-Force (Sheave Size Denoted in Inches):	460V / 60Hz 518 (8.0") or 642 G's (9.0") 360V / 50Hz 445 G's (9.0")	460V / 60Hz 403 G's (10.5") or 526 G's (12.0") 360V / 50Hz 426 G's (13.0")
Screen Opening Sizes:	0.008" (0.2mm) to 0.04" (1.0mm)	0.008" (0.2mm) to 0.04" (1.0mm)
Gear Box Ratio:	74:1	71:1
Lubrication System	Oil Sealed Gearbox	Oil Sealed Gearbox
Screen Surface Area:	7.11 sq. ft. (0.661 sq. m.)	13.3 sq. ft. (1.25 sq. m.)
Motor Horsepower:	30 hp (22.71 kw)	75 hp (60 kw)
Voltage:	460v / 60Hz or 380V / 50Hz 3-Phase (Dual rated Inverter-Duty Motor)	460v / 60Hz or 380V / 50Hz 3-Phase (Dual rated Inverter-Duty Motor)
Electrical Classification:	Class I – Division I Explosion Proof – Group D (Temp. Rating of 55° C)	Class I – Division I Explosion Proof – Group D (Temp. Rating of 55° C)
Dimensions (without stand):	7' (2.1 m) L x 6' (1.8 m) W x 5' (1.5 m) H	8.10' (2.5 m)L x 7.3' (2.2 m)W x 5.9' (1.8 m)H
Weight (Without Stand):	4,400 lbs (1,995 kgs)	7,700 lbs (3,492 kgs)

## Screw Conveyors

Did you know that Elgin offers a full line of Shafted and Shaftless Screw Conveyors. These systems are ideal for feeding wet cuttings to the VCD or moving discharged cuttings away from the unit for disposal.

Available in 12-Inch or 14-Inch widths in a variety of lengths depending on your operational needs.



Model Number:	CSI-D3 Cyclone Pro™	CSI-D4 Cyclone Pro™	CSI-D5 Cyclone Pro™
Equipment Image:			
Feed Capacity:	40 TPH (40 m³/h)	80 TPH (80 m³/h)	100 TPH (100 m³/h)
Maximum G-Force:	460V / 60Hz 300 to 700 G's (VFD) 360V / 50Hz 300 to 500 G's (VFD)	460V / 60Hz 300 to 550 G's (VFD) 360V / 50Hz 300 to 450 G's (VFD)	460V / 60Hz 300 to 550 G's (VFD) 360V / 50Hz 300 to 450 G's (VFD)
Screen Opening Sizes:	0.008" (0.2mm) to 0.04" (1.0mm)	0.008" (0.2mm) to 0.04" (1.0mm)	0.008" (0.2mm) to 0.04" (1.0mm)
Gear Box Ratio:	VFD Variable	VFD Variable	VFD Variable
Lubrication System	Oil Sealed Gearbox	Oil Sealed Gearbox	Oil Sealed Gearbox
Screen Surface Area:	7.11 sq. ft. (0.661 sq. m.)	13.3 sq. ft. (1.25 sq. m.)	15.5 sq. ft. (1.44 sq. m.)
Motor Horsepower:	(1) 25 hp (18.3 kw) & (1) 5 hp (3.7 kw)	(1) 60 hp (44.74 kw) & (1) 15 hp (11.19 kw)	(1) 75 hp (55.16 kw) & (1) 20 hp (14.71 kw)
Voltage:	460v / 60Hz or 380V / 50Hz 3-Phase (Dual Rated Inverter-Duty Motor)	460v / 60Hz or 380V / 50Hz 3-Phase (Dual Rated Inverter-Duty Motors)	460v / 60Hz or 380V / 50Hz 3-Phase (Dual Rated Inverter-Duty Motors)
Electrical Classification:	Class I – Division I VFD Explosion Proof – Group D (Temp. Rating of 55° C)	Class I – Division I VFD Explosion Proof – Group D (Temp. Rating of 55° C)	Class I – Division I VFD Explosion Proof – Group D (Temp. Rating of 55° C)
Dimensions (without stand):	84" (2,134 mm) L x 62" (1,575 mm) W x 56" (1,422 mm) H	101" (2,565 mm) L x 71" (1,803 mm) W x 76" (1,930 mm) H	101" (2,565 mm) L x 74" (1,880 mm) W x 78" (1,981 mm) H
Weight (Without Stand):	3,900 lbs (1,769 kgs)	8,300 lbs (3,765 kgs)	9,400 lbs (4,264 kgs)

Elgin's engineering team can also provide full plant engineering services for semi-permanent and permanent waste management systems.

Elgin's product portfolio provides a "one-stop" shop for any solids control management or waste management challenge.

