



Hyper-G™ Shale Shaker Product Overview

2024

Natural Resource Recycling • Product Classification • Dewatering • Fluid Recovery
Waste Management • Material Handling • Liquid/Solid Separation • Crushers • Feeders

TERRASOURCE
GLOBAL

OUR FLAGSHIP BRANDS

GUNDLACH
CRUSHERS

JEFFREY RADER

Pennsylvania
Crusher

ELGIN

Full-Service OEM

Engineering, Design, Manufacturing, Commissioning and Servicing



Decanter Centrifuge



Vibrating Screens



Vibratory Centrifuge



Vertical Cuttings Dryers

Natural Resource Recycling • Product Classification • Dewatering • Fluid Recovery
Waste Management • Material Handling • Liquid/Solid Separation • Crushers • Feeders



Hyper-G™ Shale Shaker

Multiple Configurations for Operational Needs



3-Panel Shaker



4-Panel Flow Line



6-Panel Shaker

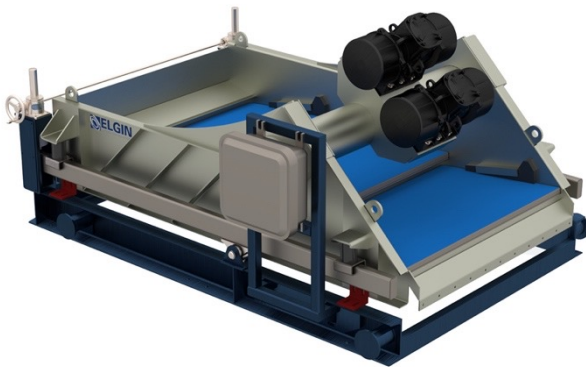

3-Panel Drying Shaker

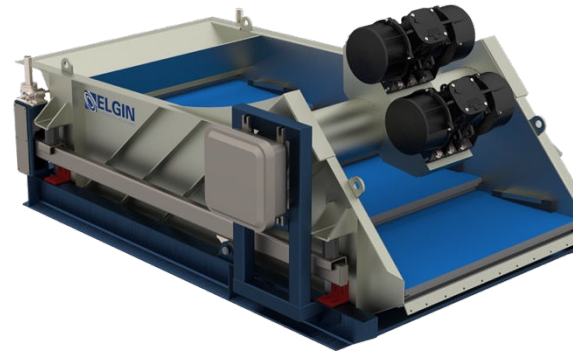

4-Panel Drying Shaker



6-Panel Drying Shaker

Depending on your operations, Elgin's has the right shaker to maximize performance.



Hyper-G™ Shale Shaker

Product Innovation – Dual Motion, Multi-G, Progressive G' Shaker



Motor Setting	Dual Motion Balanced Elliptical Motion	Dual Motion Linear Motion	Fixed Motion High-G
Low G	4.5	5.0	N/A
Mid G	5.5	6.0	N/A
High G	6.0	6.5	7.5

Elgin Separation Solutions' Dual Motion Hyper-G™ allows operators to select both the G-force and the excitation pattern (linear motion or balanced elliptical motion) with a single on-board NEMA 7X explosion-proof VFD system.



Shaker Screen Performance

Improved Liquid/Solid Separation with Composite Screens

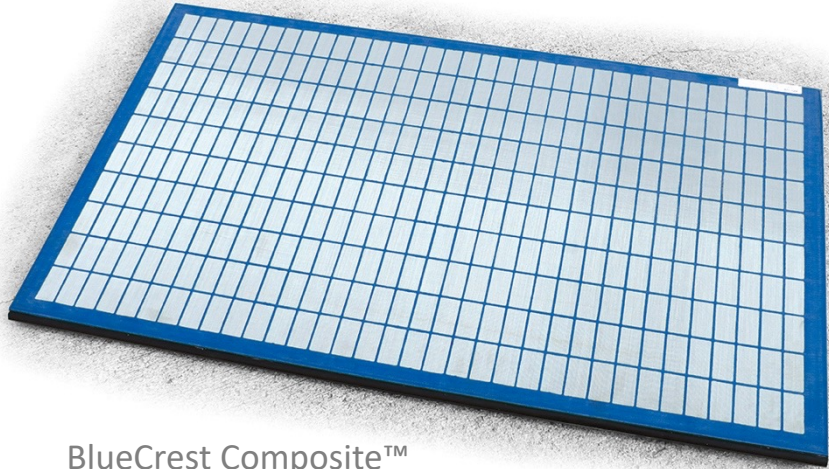

BlueCrest Composite™

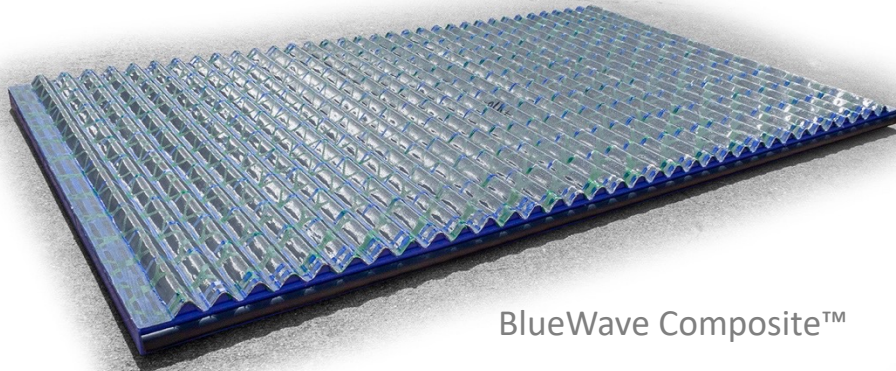

BlueWave Composite™

Elgin's BlueWave Profile Provides for a
40% Increase in Screening Surface Area.

Composite screens optimize solids control efficiency to reduce costs and waste volumes, regardless of the targeted formations and drilling applications.

- **Performance** – Elgin's Composite screens provide higher surface tension.
- **Quality** – Composite screens inherently have a higher quality control.
- **Resists Premature Delamination** – Composite screens are not laminated. As such, there is no ability for the perforated plate or the wire mesh to prematurely separate from the frame.
- **Composite Polyurethane Technology** – New manufacturing technology has advanced shaker screen construction using composite material with steel reinforcement.
- **Storage Life** – Composite screens frames do not dent or warp from mishandling.

Shaker Screen Performance

Improved Liquid/Solid Separation with Composite Screens

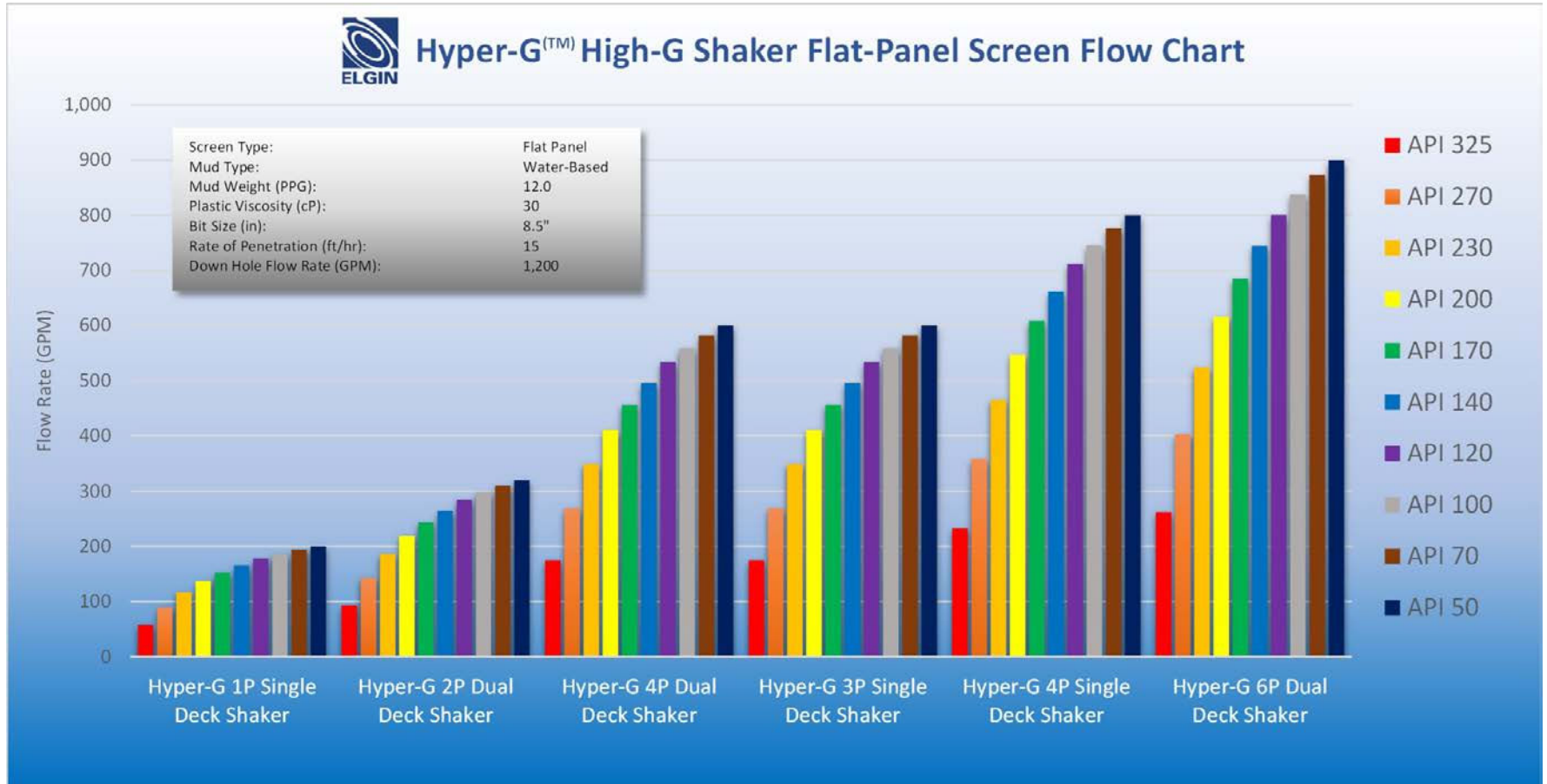

Composite screens provide for higher tension of woven wire cloth. As such, they provide for an improved cut point and extended wear life.

Hyper-G™ Shaker

Performance

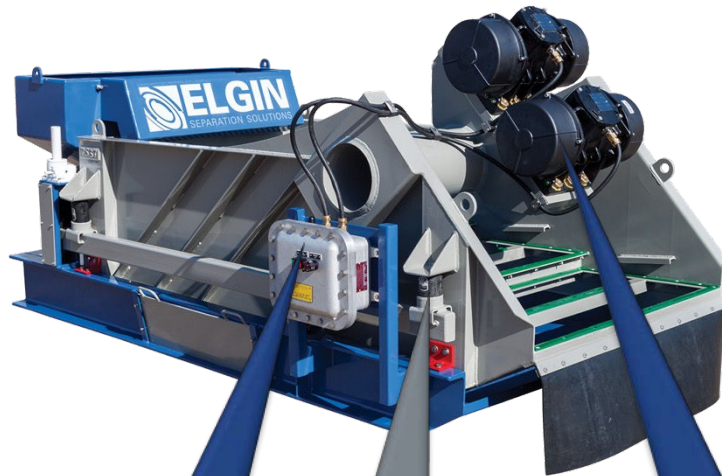

NEMA 7X Class I –
Division I VFD
Panel provides
multiple G-forces
in both linear and
balance elliptical
motion.

One-piece
Firestone
Marshmallow
Springs maximize
G-force while
minimizing
carriage vibration.

Dual 2.5HP
Explosion-Proof
High-G motors
provide up to 7.5
G's of force.

Multi-functional
High-G motors
generate both
linear and
balanced elliptical
motion.

Fully balanced,
adjustable while
drilling single-point
jacking system.

Elgin's Dual Motion Hyper-G™ shale shaker allows operators to tune one shaker for any hole or drilling fluid condition experienced.



Hyper-G™ Shaker

Proprietary Progressive G-Force Profile

Relative G-Force at
Screen Surface

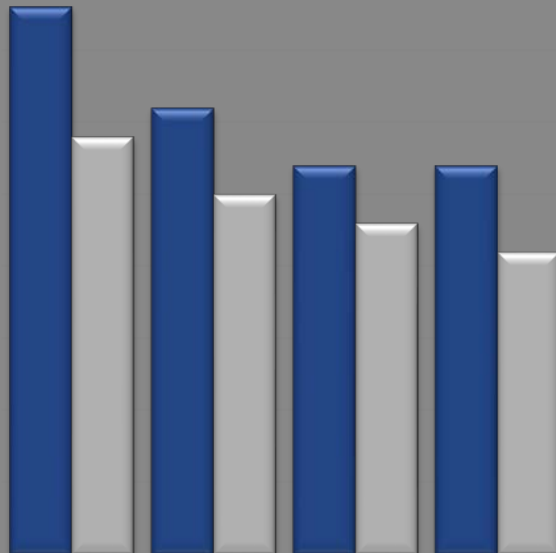

Screen 1 Screen 2 Screen 3 Screen 4

■ High Linear Motion

■ High Balanced Elliptical Motion

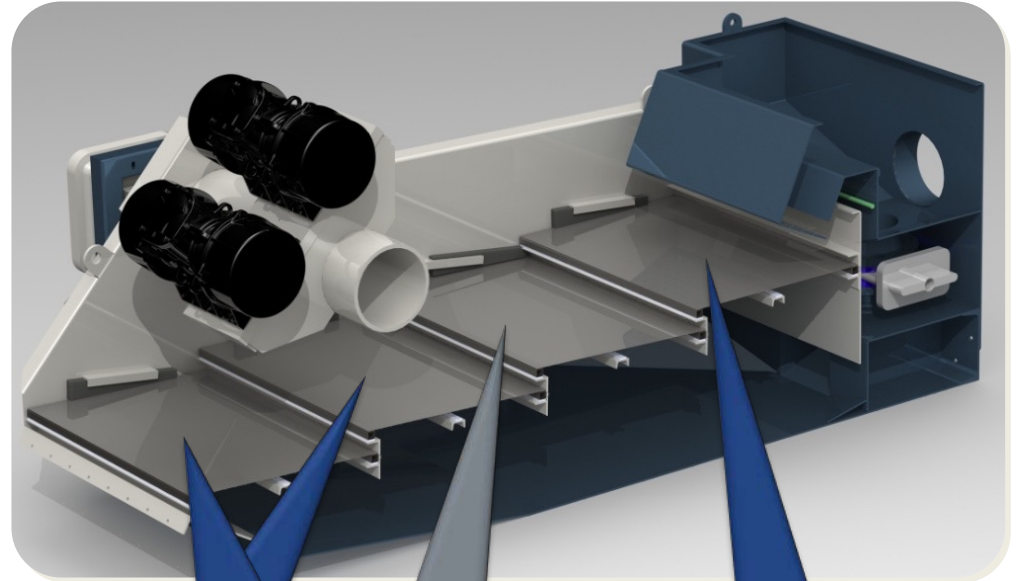

G-force and conveyance is further reduced to minimize solids degradation and maximize dryness.

G-force and conveyance are lowered to minimize solids degradation.

Maximum conveyance and G-force is applied to the entry screen.

To ensure that excessive G-force is not being applied, when not called for, the on-board VFD allows for optimum system fine-tuning.

Hyper-G™ Shaker

Installation Flexibility

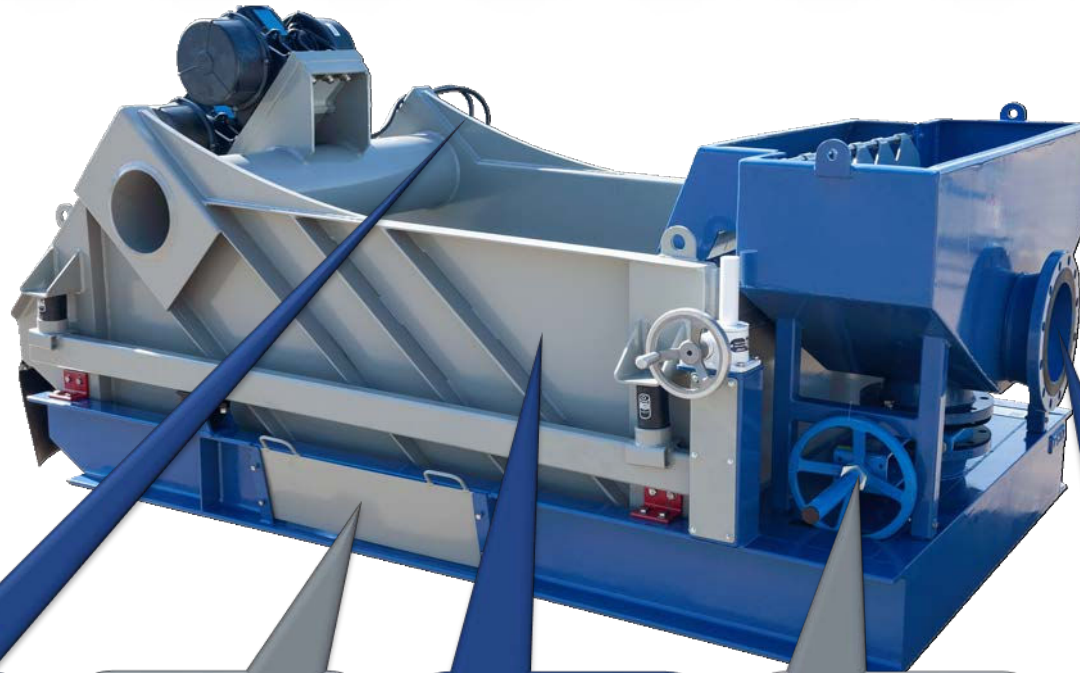

Reversible control panel that can be placed on the left or right side of the shaker.

Dual single-piece flow diverters allow for mud to be managed to either side of the shaker.

Fully-balanced shaker basket allows for deck angling with minimal effort while drilling.

New conveniently located knife-gate provides for seal-tight mud by-pass capability.

10" inlet flange provided directly on rear of one-piece possum-belly / gumbo tray.

The Hyper-G™ Shaker was designed for maximum installation flexibility, regardless of the rig or the current assets utilized.

Hyper-G™ Shaker

Ergonomics and Durability



Rated lifting eyes located at the top of the shaker basket improves handling.

Single-piece tubular steel for maximum energy translation & lower weld stress.

Single-piece rigid motor mount truss maximizing energy translation & lowers weld stress.

¼" ASTM A36 plate steel construction, full seam welded for maximum equipment life.

Fully integrated "gumbo tray" and "possum belly" ensures strength and stability.

Ensuring Operator Safety Remains a Fundamental Commitment to Elgin's Design Philosophy.

Hyper-G™ Shaker

Mud Management



Integrated “gumbo tray” and “possum belly” eliminate possibility of mud by-pass into the carriage.

“Gumbo tray” designed with integrated flow diffusion device to minimize physical wear on the screens.

New single piece wedge ensures that sufficient pressure is applied to seal the screens to the basket.

Elgin's proprietary “water-fall” staggered screens eliminate solids bypass between screens.

Integrated mud skirt lip allows for smooth discharge of solids directly into a conveyor or tank.

By significantly improving the design, Elgin has been able to extend a three-year warranty with its Hyper-G™ Shaker.

Hyper-G™ Shaker

Lower Total Cost of Ownership



“Crown rubbers” have been eliminated within Elgin's Hyper-G, replaced by durable polyurethane strips.

Firestone™ Marshmallow Springs provide for a one-piece design. Does not corrode or require repainting.

Fully powder-coated construction provides for excellent wear and abrasion resistance.

Dual single-point jacks have been designed with a performance factor of 4 to ensure maximum life.

Low pressure water knife gate with radial seals will ensure a tight seat and minimal maintenance.

Most importantly, Elgin's new Hyper-G shaker comes with an unbeatable, industry leading, 3-Year Limited Warranty.

Hyper-G™ Specifications

Shaker Designs for Operational Needs

Model Number:	Hyper-G 3P™	Hyper-G 4P™	Hyper-G 6P™	Hyper-G 3PDS™	Hyper-G 4PDS™	Hyper-G 6PDS™
Equipment Image:						
Screen Type:	Hyper-G BlueCrest 28 Composite	Hyper-G BlueCrest 26 Composite	Hyper-G BlueCrest 28 Composite	Hyper-G BlueCrest 28 Composite	Hyper-G BlueCrest 26 Composite	Hyper-G BlueCrest 28 Composite
Vibratory Motors:	(2) 2.0HP (1.49kW)	(2) 2.5HP (1.86kW)	(2) 2.5HP (1.86kW)	(2) 2.0HP (1.47kW)	(2) 2.5HP (1.86kW)	(2) 2.5HP (1.86kW)
Number of Screen Panels:	Three (3) Panels	Four (4) Panels	Six (6) Panels	Three (3) Panels	Four (4) Panels	Six (6) Panels
Screen Surface Area:	28 sq. ft. (2.6 m ²)	35 sq. ft. (3.25 m ²)	56 sq. ft. (5.2 m ²)	28 sq. ft. (2.6 m ²)	35 sq. ft. (3.25 m ²)	56 sq. ft. (5.2 m ²)
Maximum Flow Rate:	650 gpm (41 lps)	750 gpm (48 lps)	1250 gpm (79 lps)	650 gpm (41 lps)	750 gpm (48 lps)	1250 gpm (79 lps)
Weir Height:	30" (76 cm)	33" (83 cm)	40" (102 cm)	N/A	N/A	N/A
Length:	117" (297 cm)	127" (322 cm)	112" (284 cm)	96" (244 cm)	108" (274 cm)	108" (274 cm)
Width:	79" (200 cm)	79" (200 cm)	79" (201 cm)	69" (175 cm)	79" (200 cm)	82" (208 cm)
Maximum Height:	54" (137 cm)	58" (147 cm)	65" (165 cm)	52" (132 cm)	58" (147 cm)	65" (165 cm)
Weight:	4,586 lbs (2,080 kgs)	4,850 lbs (2,200 kgs)	5,300 lbs (2,404 kgs)	3,000 lbs (1,361 kgs)	4,500 lbs (2,041 kgs)	4,200 lbs (1,905 kgs)

Hyper-G™ Shaker

Key Features

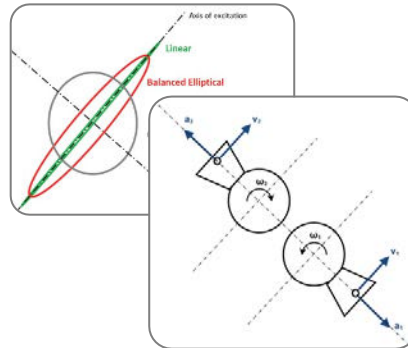
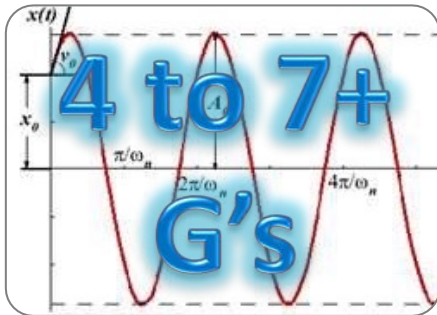

Power On-Demand Power

With a redesigned basket & motors, the Hyper-G™ is Elgin Separation Solution's most powerful variable G shaker, therefore allowing the operator to tune the shaker to the drilling program.

Motion Selectable Motion

By the simple turn of a switch the Hyper-G™ can generate either linear motion or balanced elliptical motion, therefore allowing the operator to tune the shaker to the cuttings.

Durability Three-Year Warranty

By focusing on quality and value, Elgin Separation Solution's Hyper-G™ maintains the industry's most aggressive three-year warranty.

Closing the WBM & OBM Loop

Integrated Solids Control and Waste Management Products.

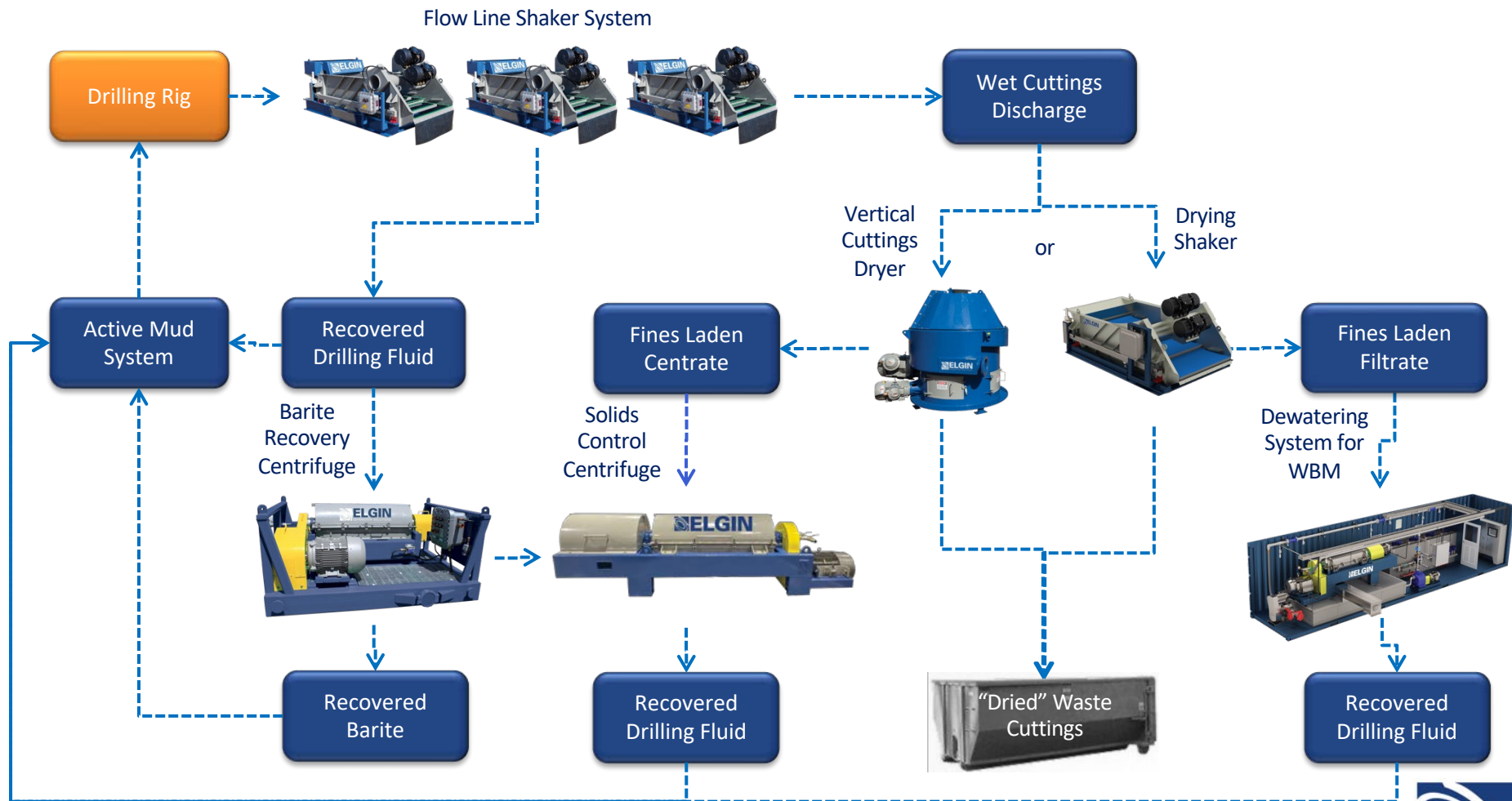

Elgin's product portfolio provides a "one-stop" shop for any solids control management or waste management challenge.



A member of TERRASOURCE

Elgin Value

Definitive Value Proposition in Utilizing Elgin Shakers

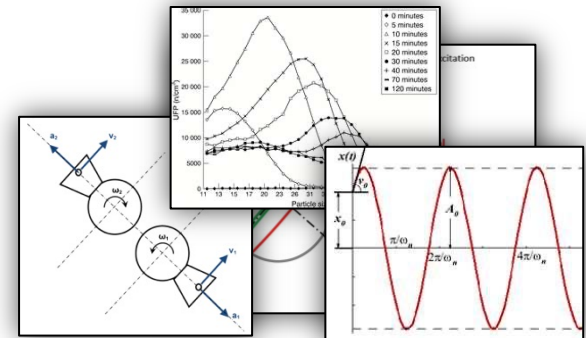

Unsurpassed Experience

Elgin Separation Solutions has shipped shakers to over 40 different countries over the last 25 years and continues to provide local support and maintenance in 16 different countries.

Unsurpassed Durability

With more than 30 years of experience building shakers for the oil and gas industry, Elgin Separation Solutions has developed a reputation for the most durable systems in the market. The average asset life exceeds 10 years with proper preventative maintenance.

Engineering Support

Elgin's dedicated Engineering team evaluates system hydraulics, frictional losses, predictive reliability, and failure mode evaluation analysis ("FMEA") for each shaker designed. Months of product validation testing is performed prior to the release of any Elgin shaker.

Elgin manufactures its own spare parts and consumables ensuring 100% integrated accountability for the entire shaker.



Hyper-G™ Shale Shaker Product Overview

2024

Natural Resource Recycling • Product Classification • Dewatering • Fluid Recovery
Waste Management • Material Handling • Liquid/Solid Separation • Crushers • Feeders

TERRASOURCE
GLOBAL

OUR FLAGSHIP BRANDS

GUNDLACH
CRUSHERS

JEFFREY RADER

Pennsylvania
Crusher

ELGIN