

ELGIN

Mining, Aggregate, and Water Solutions

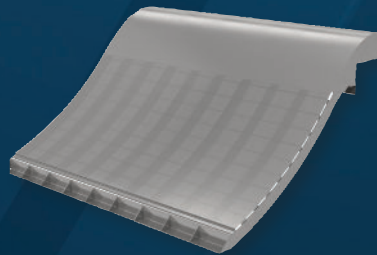
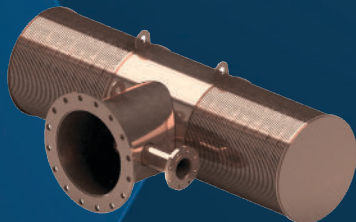
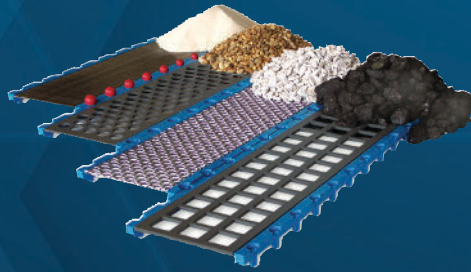

Natural Resource Recycling • Product Classification • Dewatering • Fluid Recovery
Waste Management • Material Handling • Liquid/Solid Separation • Crushers • Feeders

TERRASOURCE
GLOBAL

OUR FLAGSHIP BRANDS

GUNDLACH
CRUSHERS

JEFFREY RADER

Pennsylvania
Crusher

ELGIN

Vibrating Screens

Horizontal Screen

The linear-motion Horizontal Screen is the mainstay of the many screens used in coal prep plants and lends itself toward sizing when the cut point is below 1½". It is also used in magnetite recovery and dewatering.



Reverse Incline Screen

Reverse Incline Screens are often used for dewatering and recovery of fines from effluent. With its high acceleration and upward slopes, this screen is suitable for applications where a dry, conveyable product is needed.



Incline Screen

Linear-motion Incline Screens are used primarily in the aggregate industry where production volume has increased but space limitations do not allow for larger screens.

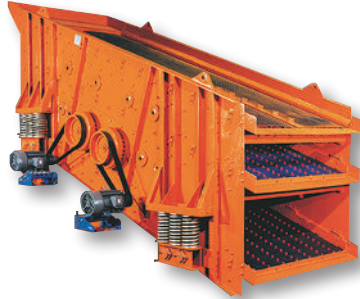

Multi-Slope Screen

This screen is used in almost every coal industry application, particularly in raw coal/deslime and drain/rinse operations.



Circular-motion Incline Screens typically lend themselves to scalping operations. The circular motion causes the material to roll down the deck. This helps reduce "plugging" of the near size material in the openings. Elliptical-motion Incline Screens operate in much the same way as the circular motion version. Depending on drive placement, this screen can speed up the travel rate on the feed end and slow it down on the discharge end.

It increases processed tonnage 30% to 40% over the same footprint of a conventional type screen.

The operating principle of the "banana" screen is based on maintaining a thin bed of material from the feed to discharge end. This allows immediate stratification of fines to the bottom of the bed and increases the probability of separation. The TMS Multi-Slope screen has standard 4' modular deck sections and replaceable deck wear liners.

Feeder

Elgin Feeders are custom designed to offer either a coarse separation or solid plates for conveyance. They are available in various sizes ranging from 4' x 8' wide and up to 30' long. We offer numerous types of liner and grizzly bar material options to suit the toughest applications.



Screen Type	Sizes	Deck Configuration	Surfaces
Horizontal	3'W x 8'L to 12'W x 24'L	Single & Double	Woven Wire Profile Polyurethane
	4'W x 12'L to 8'W x 24' L	Triple	
Incline	4'W x 12'L to 10'W x 24'L	Single & Double	Rubber Perforated Plate
	4'W x 12'L to 8'W x 24'L	Triple	
Reverse Incline	3'W x 8'L to 8'W x 12'L	Single	Custom Design
Multi-Slope	6'W x 20'L to 14'W x 24'L	Single & Double	

Vibrating Screens

FAG Remote Monitor

The FAG Remote Monitor gives you immediate feedback on the condition of your drive bearings. If a problem arises, the monitor notifies you on any computer terminal or smart device.



QuickChange Removable Spring Seat

Simplify spring changes with the QuickChange Removable Spring Seat system. It reduces the amount of hoisting required, allowing for faster, safer, and easier steel coil replacement in a fraction of the time.

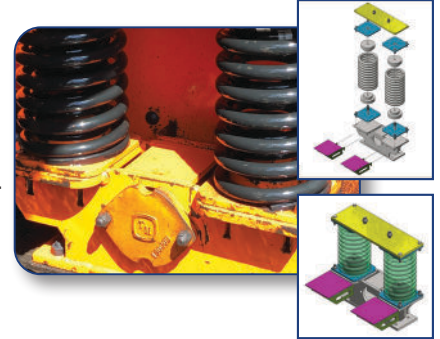

Independent Cross Members

Independent Cross Members provide exceptional strength at a fraction of the weight of one-piece deck assembly.

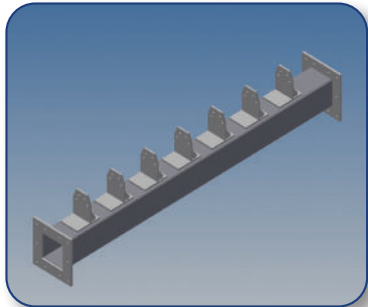

For installations where weight is an issue, this optional solution can help reduce the overall weight of the screen by as much as 30%, without sacrificing performance and durability.

Plus, independent cross members are huck-bolted to the side plates, allowing for faster replacement of any cross member. This reduces downtime and makes maintenance safer for personnel.

24/7 Customer Service

Our Customer Service department is available 24/7, every day of the year. That means we are always ready to help connect you with the parts you need.

Our responsive customer service team is supported by a fully computerized parts inventory, a generous replacement pool, and our own truck fleet for local deliveries. That means your parts are available, picked, and delivered – fast.

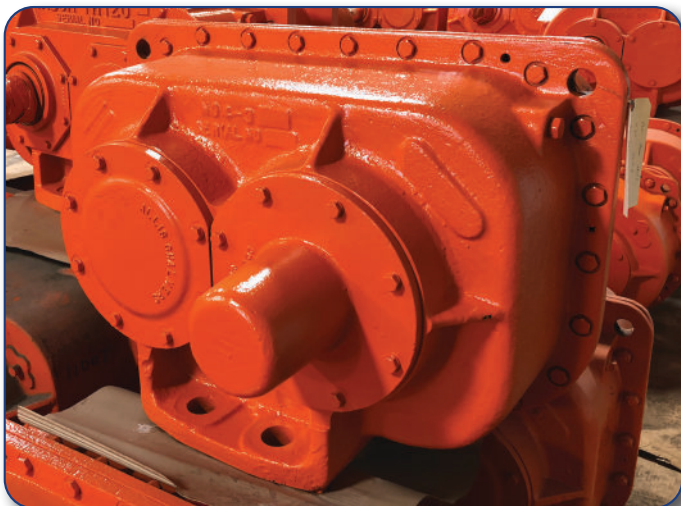

Long-Lasting TH Drives

We know you need to keep business moving. So we build our Tabor TH Drives to last an average of 8-10 years. Plus, optional polyurethane coating on the drive bottom helps extend the life even more.

We also offer an incredible Drive Rebuild/Exchange Program. If your drive ever does need repaired or replaced, we will exchange it for a new or rebuilt drive that carries a full one-year warranty.

Tabor TH linear-motion drives are available in 100, 120, 140, and 160 configurations. Your Elgin engineer will recommend the best drive for your needs, based on the size of the screen and the materials application.

Profile Wire and Polyurethane Screens

Tabor-Thane Polyurethane

Panels easily install in stringers. A locking pin is then hammered in to double lock panels in place. Dams attach using double locking pins in place of single pins. Optional Pin Strips can be used in place of single pins.



Modular Panels

Our patented Polyurethane Screen Systems can be used on almost all OEM vibrating screen manufacturers for sizing, rinsing, and dewatering your product. We also offer hybrid screen decking available in woven wire, perforated plate, and profile wire to maximize your screen's efficiency.



12" x 12" & 1' x 4' Panels

Construction Features:

- 4 Pin and 6 Pin
- Plug Free Panels
- Square Holes, Slots
- Patented Locking System
- Openings from .25 mm to 3"
- Thickness: Up to 2"

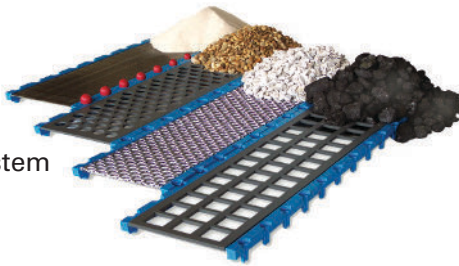

Curved Static Sieve

Curved Sieves efficiently remove debris from incoming flow. The screens utilize the coanda effect to improve efficiency, while using gravity and overflowing water to remain clean during storm events.

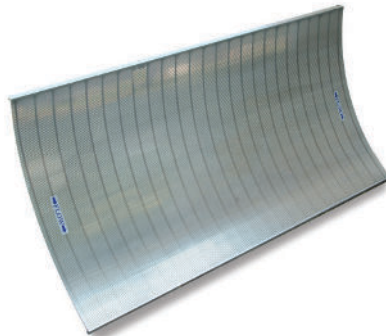

Tabor-Thane Pinless System

This user-friendly design provides flexibility, simple installation, and ease of maintenance. It's designed for maximum user flexibility. The support system can accommodate various screen configurations and hole openings, and it can be installed on most other deck frame designs. It can be quickly installed or changed, reducing operational down time and lost production.

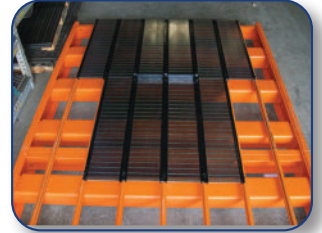

Profile Wire Screens

Unlike punch plate or woven wire, Profile Wire Screens offer 2-point particle contact. The continual slots and inward widening openings allow for less plugging of near size particles.



To ensure the strongest weld possible, we use continuously controlled TIG welding to connect the profile wires to the support bars.

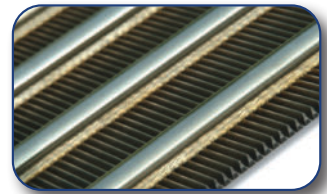

Profile Wire Sizes

NORRIS PROFILE WIRES			
	Angle		
	13 Degree Profiles		"W" (.030) (.060) (.090) (.120) "H" (.177) (.100) (.156) (.203)
	10 Degree Profiles		"W" (.070) (.105) (.186) "H" (.177) (.324) (.344)
	5 Degree Profiles		"W" (.090) (.120) (.155) (.186) "H" (.170) (.218) (.286) (.344)

Hard Chrome Plating

For high wear problems, hard chrome plating can be added to increase your screen's wear life.

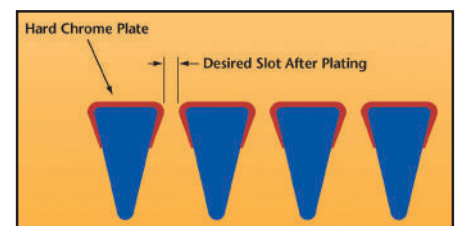

Mining and Aggregate Industry Products

CMI-EBR/EBW Vertical Screen Scroll

Elgin Model EBR/EBW Vertical Screen-Scroll Centrifuges are designed for small particles and will provide efficient and consistent moisture reduction even with fluctuating feed rates.



Available in 36", 40", 40" HTS, 42" & 48"

CMI-HVC Horizontal Vibratory Centrifuge

Available in either a 1000, 1400 or 1500 configuration, the HVC Horizontal Vibratory Centrifuge is easily installed in nearly every coarse particle circuit. With its cartridge-style drive assembly allowing for quick field replacement and its economical low G operation, the HVC is designed with ease of operation in mind. Available with a two-piece screen configuration for replacement cost savings.



CMI-HSC Horizontal Screen Scroll

The HSC is designed to be user friendly while lowering the cost of installation, operation, maintenance and repair. With its sealed, nearly maintenance-free drive unit, simplified lubricating system, sealed oil-filled planetary gearbox, and self-contained construction, the HSC is rugged and reliable yet cost-effective. The HSC Horizontal Scroll comes with a unique I-Beam and Chain Hoist system, which allows maintenance without need of an overhead crane.



CMI-VC Vertical Vibratory Centrifuge

The VC Centrifuge uses vibratory dewatering technology and centrifugal force to provide reliable dewatering of coarse particle applications. A large feed hopper eliminates the need for a feed chute, and a catch in the center increases part life. The VC features an accelerating wear plate which allows for even screen wear. The drive assembly consists of the main working parts enclosed in a steel cast housing, which can then be removed as a single unit for easy replacement or repair.



Rotary Breaker

Featuring dual- or single-end drives, Elgin's Rotary Breakers lift and drop feed material several times as it traverses through the drum, to size the material and scalp undesirable material. Desirable-sized material passes through screen perforations and into a product hopper. Undesirable material traverses through the breaker and out the discharge end for disposal. The simple design of a rotary breaker requires little maintenance, making it economical and easy to operate.



Sizes Available:

12' Diameter x 16', 20', 24' and 27' Length

10' Diameter x 16', 20' and 24' Length

9' Diameter x 16', 18', 20' and 24' Length

Teeter Bed Separator

Elgin's Teeter Bed Separator (TBS), also known as a hindered settling classifier, uses a continuous upward current of water to provide separation by specific gravity. The computerized electronic control system automatically monitors the TBS operating conditions and makes necessary adjustments to maintain efficiency in separation.



The TBS is available in sizes ranging from 2 ft. in diameter (TBS 600) to 13 ft. in diameter (TBS 4000). Regardless of the application or the tonnage requirements, Elgin can offer a TBS Model to accommodate your needs.

Mining and Aggregate Industry Products

Chute Work

Elgin can design and manufacture chutes to fit your needs. Built using A36 steel or stainless steel and designed for durable long-life performance, our pre-engineered chute lining protects and cushions the chute from the material being handled. Ceramic liners deliver ultimate performance where extreme heat and abrasion is a problem.



Liners Available: 550 Brinell, AR400, Tri-Braze, Stainless Steel, Tivar 88 (1/4" up to 1" thickness)

Thermal Dryers (Cyclones)

Elgin manufactures replacement parts for ENI and other types of Thermal Dryers, including ductwork, explosion doors, grate rods, support beams, dust cyclones, mist eliminator stacks, and more. Materials include mild steel and 309 and 316 stainless.



Sieve Bends & Feed Boxes

Elgin's Sieve Bend combines unique features with durability that generates one of the lowest cost per ton processed feed available on the market today. Sieve screens are made of stainless steel for corrosion and wear resistance.

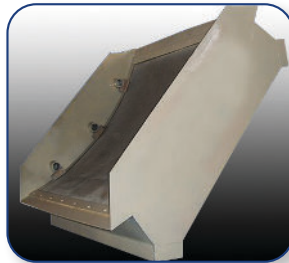

Improved box and feed chute design permits full utilization of screens and controls splashing and flooding of the screen. Includes ceramic liners for extended wear life.



Power Plant

Elgin designs and produces general and custom fabrication for coal-fired and natural gas-fired electric producing power plants, including chute work, bins, ductwork, boiler casings, walkways, platforms, and stairs. Our precision production shop can work with mild and stainless steel, nitronic 30, SA387 Grade 11 and Grade 22, AR400F, and various clad plates. Our onsite PE and engineering team will work with you before and after installation to ensure the right solution for your needs.



Belt Wiper

Elgin Belt Wipers are made of polyurethane, offering advantages such as abrasive, tear and impact resistance. Belt Wipers come in solid or segmented designs that are easy to replace. Blades are water, oil, and grease resistant.



Industrial Heater

Elgin manufactures industrial heavy-duty forced air electrical heaters in 30 kW and 50 kW configurations. Constructed from galvanized steel or stainless steel with helical wound elements using chrome resistance wire.



Full Service Custom Fabrication and Repair

Clinch River Corporation provides high quality industrial metal fabrication and vacuum pump repair, with versatile production capabilities to serve a wide range of industries. Clinch River Corporation is also a certified distribution and service center for Howden Roots Vacuum Pumps to keep your operation up and running.



Water Intake Solutions

Coanda Screens

Coanda screens use tilted wedge wire to provide water to hydro, municipal water, and other facilities. Clean water falls through while fish and debris pass over. A Coanda screen allows operators to simplify the intake structure by supplying a higher level of filtration in a smaller area when compared to a traditional intake.

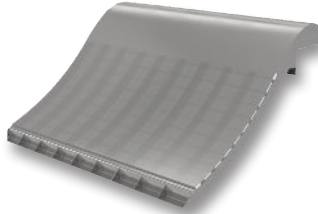

Screen Cleaning Systems

We believe the basis for an effective cleaning system is reliability and simplicity. Our AirBurst systems deliver compressed air to remove debris from the surface of the screen. Common components make maintenance a breeze and stationary parts eliminate the need for complex retrieval systems. An IceBreak option can be added to prevent the rapid blockage associated with frazil ice.



Cylindrical Screens

Cylindrical screens use a combination of physical and hydrodynamic exclusion so that the screens do not clog or kill fish. The screens can include AirBurst systems to remove any debris, and a variety of other technologies to protect your water supply.

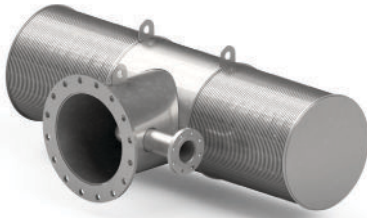

Copper Nickel Coating

Copper nickel has been proven for decades to resist corrosion and fouling by zebra mussels. This alloy has the effectiveness of copper without leaching into your water source. Elgin offers both a copper nickel coating and copper nickel construction.

The coating is a patented process (U.S. Patent #5,945,171) that utilizes the same alloy as our base material screens, but results in a much stronger and cost-effective solution. In contrast to foul release coatings, our solutions will last the lifetime of the screen system.



Flat Panel Screens

Elgin's wedge wire flat panel screens are able to withstand extreme loads and adhere to precise tolerances. With fabrication methods tailored to the mining industry, our screens can handle anything your water source can throw at it. Flat panel screens can fit into existing openings or can be supplied with guide rails to ensure smooth installation and serviceability over the life of the product.

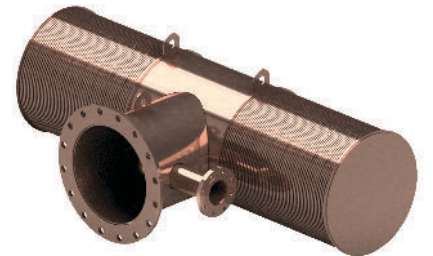
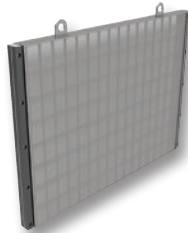

NSF Certification

Elgin Water Solutions has earned NSF certification for Jacquelyn Coating, which was the result of extensive testing and an audit of our quality control procedures.



Side Hill Screens

Elgin's Side Hill Screen requires no power or special inputs on site to operate. This minimizes capital and operating costs. The wedge wire screen efficiently captures water while delivering dewatered debris to the desired location. This assembly is available in stainless steel construction (304 or 316). Optional features include: hinged top enclosure, extended discharge lip, spray bars, and non-standard inlet/outlet fittings.





**With offices and joint ventures worldwide,
Elgin provides unparalleled solutions and support when you need it most.**

Founded in 1864 in Elgin, Illinois, Elgin has evolved into a worldwide leader in design, manufacture, and service of specialized processing equipment in the Oil & Gas, Mining, Coal, Aggregates, Minerals, Rendering, Dredging, Water, and Pipeline Construction industries. Elgin specializes in the full integration of solids conveyance systems, sophisticated PLC-driven automation systems, and product life-cycle management repair and remanufacturing services.



Turn-Key Solutions Provider

Innovation Leaders

Elgin Separation Solutions design philosophy brings new technology, improved efficiency, and automation control systems to meet the demands of today's operator.

Quality Manufacturers

Every stage of Elgin's turn-key manufacturing process is quality controlled to ensure the finished product exceeds the requirements for today's operating environments.

Flexible Customization

Elgin Separation Solutions specializes in working with each customer to design the perfect turn-key system that meets their operating needs for maximum production.

Customer Driven

Elgin is driven to turn the basic capital equipment procurement process into a relationship that extends through the entire life of the products, systems, and services supplied.

Vibrating Screens / Fabrication Services

1176 Shelter Road, Princeton, WV 24739
Phone: 304-431-4100

Vibratory Centrifuges / Screen Scrolls / Rotary Breakers

5595 Highway 34 North, Raleigh, IL 62977
618-268-4850 (CSI), 314-776-2848 (CMI)

Polyurethane / Profile Wire Screens

21405 Gov. G.C. Peery Hwy., Tazewell, VA 24651
Phone: 276-988-8901

Coanda Screens / Flat Panel / Cylindrical Screens / Copper Nickel Coating

5 South High Street, Canal Winchester, OH 43110
Phone: 614-524-4588

www.elginseparationsolutions.com

Natural Resource Recycling • Product Classification • Dewatering • Fluid Recovery
Waste Management • Material Handling • Liquid/Solid Separation • Crushers • Feeders

